

## U-MAD® | TRUCK MOUNTED ATTENUATOR

- MEETS NCHRP 350 CRITERIA  
WITH ARROW / MESSAGE BOARD ATTACHED
- CARTRIDGE INTERCHANGEABLE WITH U-MAD TRAILER
- PARTIALLY REUSABLE TMA
- COST EFFECTIVE SOLUTION



## PHYSICAL SPECIFICATIONS

Classification	70K TMA	100K TMA
Length	9' 5"   2.89 m	13' 8"   4.19 m
Width	90"   229 mm	90"   229 mm
Height   Up Position	8' 3"   253 cm	12' 6"   381 cm
Test Level	TL-2	TL-3

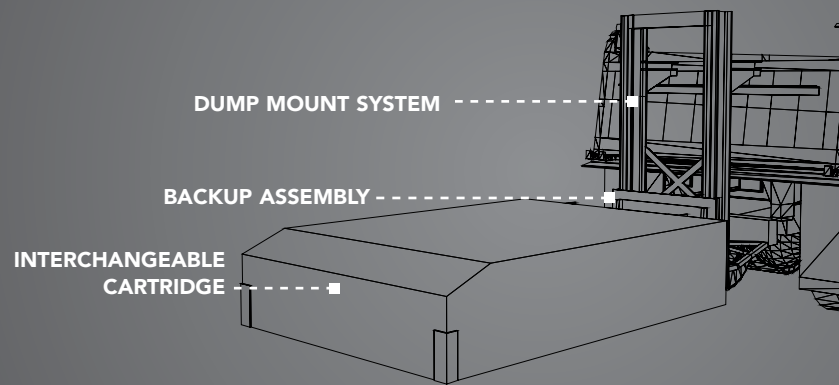

## TL-2 & TL-3 TMA PROTECTION IN A REUSABLE DESIGN

U-MAD Truck Mounted Attenuators (TMAs) offer outstanding performance and quick, simple refurbishment. The U-MAD TMA is available as a TL-2, TL-3 or 80 km/h System for use in work zones with speed capacities from 44 - 62 mph (70 - 100 km/h). The U-MAD TMA provides a wide range of protection for workers, motorists and equipment. The U-MAD TMA has passed the rigorous NCHRP 350 TL-2 and TL-3 criteria for both mandatory and optional tests with an arrow/message board installed.

## FREQUENTLY ASKED QUESTIONS

### What is reusable after a design impact?

After a typical design impact only the cartridge needs to be replaced.

### Does the U-MAD TMA meet NCHRP 350 TL-3 optional test criteria?

Yes, the U-MAD TMA meets all required test criteria for mandatory and optional tests under NCHRP Report 350 TL-3.

### What is the cartridge replacement procedure for the U-MAD TMA?

The replacement procedure is very simple. All that is required is removing and replacing a cartridge, two bolts and a cylinder pin.

### How does the TMA attach to a truck?

The U-MAD TMA utilizes many different engineered systems for quick attachment to a host vehicle. Contact your local distributor or the Lindsay Transportation Solutions Customer Care Center for more information on truck attachment.

## FEATURES

- » Only the cartridge needs to be replaced after a design impact
- » Passes all mandatory and optional NCHRP 350 TL-2 and TL-3 tests with an arrow/message board installed.
- » Engineered to keep the impacting vehicle and support vehicle in the travel lane even after angle impacts
- » Cartridges are interchangeable with the U-MAD Trailer TMA to reduce inventory costs
- » Lightweight design
- » Many flexible mounting options
- » Optional cab-mounted controller

## DISTRIBUTED BY:



Lindsay Transportation Solutions Sales and Services, Inc.

180 River Road • Rio Vista, CA 94571 • +1 707.374.6800 U.S. Toll Free: 888.800.3691 • [www.barrriersystemsinc.com](http://www.barrriersystemsinc.com)

General details for the U-MAD TMA are subject to change without notice to reflect improvements and upgrades.

Additional information is available from Lindsay Transportation Solutions Sales and Services, Inc. © Lindsay Transportation Solutions, Inc.

PT # UMAD04-03312015